

PAPER • OPEN ACCESS

# Impact of Penetration Wind Turbines on Transient Stability in Sulbagsel Electrical Interconnection System

To cite this article: Andi Nurtrimarini Karim *et al* 2018 *J. Phys.: Conf. Ser.* **979** 012028

View the [article online](#) for updates and enhancements.

## You may also like

- [Study of Dynamic Stability Analysis in the Sigura-gura Hydro Power Plant using the Power Stabilizer System as Compensation](#)  
Zulfikar
- [Tight-Binding Quantum Chemical Molecular Dynamics Study on Depth Profile Prediction in Low Energy Boron Implantation Process](#)  
Hideyuki Tsuboi, Ai Sagawa, Hideki Iga *et al.*
- [Network allocation of BESS for improving rotor angle stability](#)  
V Diaz, R Alvarez and C Rahmann

## Recent citations

- [Optimal Power Flow the Sulselrabar 150 KV system before and after the penetration of wind power plants considering power loss and generation costs](#)  
A M Ilyas *et al*



The Electrochemical Society  
Advancing solid state & electrochemical science & technology

## 241st ECS Meeting

May 29 – June 2, 2022 Vancouver • BC • Canada  
Abstract submission deadline: Dec 3, 2021

Connect. Engage. Champion. Empower. Accelerate.  
**We move science forward**



**Submit your abstract**



# Impact of Penetration Wind Turbines on Transient Stability in Sulbagsel Electrical Interconnection System

Andi Nurtrimarini Karim<sup>1,2</sup>, Sri Mawar Said<sup>2</sup>, Indar Chaerah Gunadin<sup>2</sup>,  
Mustadir Darusman B<sup>2,3</sup>

<sup>1</sup>PT. PLN (Persero) Region Sulselrabar Area Bulukumba

Jl. Lanto Daeng Pasewang No.1 Bulukumba, South Sulawesi, 92517, Indonesia

<sup>2</sup>Department of Electrical Engineering Hasanuddin University

Jl. Poros Malino KM. 6 Borongloe Gowa, South Sulawesi, 92171, Indonesia

<sup>3</sup>Health Ministry of the Republic of Indonesia

Jl. Perintis Kemerdekaan KM. 11 Makassar, South Sulawesi, 90245, Indonesia

E-mail: rini07anika@gmail.com

**Abstract.** This paper presents a rotor angle analysis when transient disturbance occurs when wind turbines enter the southern Sulawesi electrical interconnection system (Sulbagsel) both without and with the addition of a Power Stabilizer (PSS) control device. Time domain simulation (TDS) method is used to analyze the rotor angle deviation ( $\delta$ ) and rotor angle velocity ( $\omega$ ). A total of 44 buses, 47 lines, 6 transformers, 15 generators and 34 loads were modeled for analysis after the inclusion of large-scale wind turbines in the Sidrap and Jenepono areas. The simulation and computation results show the addition of PSS devices to the system when transient disturbance occurs when the winds turbine entering the Sulbagsel electrical system is able to dampen and improve the rotor angle deviation ( $\delta$ ) and the rotor angle velocity ( $\omega$ ) towards better thus helping the system to continue operation at a new equilibrium point.

## 1. Introduction

The electric power system generally consists of generating units connected to the line to serving the load [1]. Electrical power systems with multiple machines typically channel load power through interconnection lines [2, 3]. The main objective of the interconnection channel system is to maintain continuity and availability of electricity towards increasing need of load. The growing power system can lead to weak performance of the system when experiencing interference and greatly affect the stability of the system [4].

The stability itself is divided into three major parts namely steady state stability, dynamic stability and transient stability [5]. This paper will focus on the discussion of transient stability in southern Sulawesi electrical system (Sulbagsel). It needs to get a review because the system in Sulbagsel will enter to the Power Plant Bayu (PLTB / wind turbines) large capacity in two districts of Sidrap and Jenepono which will certainly affect the topology in Sulbagsel electrical network. Changing network topology has impact on the flow of power that will affect too for the stability when a transient disturbance in the system.

Large and complex systems and their changes in instantaneous system conditions [6], usually happen to short circuit interruptions in the power system, and the sudden release or substantial burden



of the large loads. As a result of changes in working conditions of this system and the state of the system will change from the old to the new state. A short period between the two states is called a parallel or transient period. Transient stability is based on a first swing stability condition with a period of investigation in the first second of the disturbance.

To analyzing the entry of wind turbine transient condition of the Sulbagsel interconnection system is used Power System Analysis Toolbox (PSAT). PSAT is a special software to analyze power system [7]. For the computation process results used Matlab software [8]. The system will also be tested using Power System Stabilizer (PSS) which will be placed on the system to see the damping process due to transient disturbance after the PLTB is integrated in Sulbagsel system.

## 2. Research Methodology

Analysis of the stability of a generator can be seen from the angle and rotor speed using Time based program. One time-based method is Time Domain Simulation (TDS) which is an indirect method that solves the transit stability problem by solving nonlinear differential equations from numerical integration with step-by-step techniques to calculate each machine of the swing curve (angle rotor against time). The modeled Sulbagsel system was then analyzed using the help of the PSAT toolbox. This toolbox is an open source software used to analyze and study the power system [9]. This TDS approach will simulate the system during periods during the faulted and postfault interruptions as well as the interruption time found between stable and unstable times (indirectly). The maximum simulation period depends on the characteristics of a good power system in terms of modeling. This usually does not exceed 15 seconds for complex system modeling. The rotor angle velocity is used to see the deviation at the entry of the wind turbine in the system after a short circuit 3 phase impedance [10]. All operations of computing can be assessed using Graphical User Interfaces (GUI).

### 2.1. Power System Modeling

In Sulbagsel system consists of 15 generators, 44 buses, 47 lines and 34 load centers [11] that scattered in the model where the transient voltage at q-axis is constant. The wind turbine model uses the doubly fed induction generator (DFIG) type which is connected to Sidrap and jeneponto buses. All generators are connected to the Automatic Voltage Regulator (AVR). The researcher used model 3 to facilitate the analysis process [12]. Model 3 presents hydro generator. In this model, some properties of the system are regarded like inelastic penstocks which water inertia is considered, as well as ideal turbines. For analysis implicitly, static load models are also used.

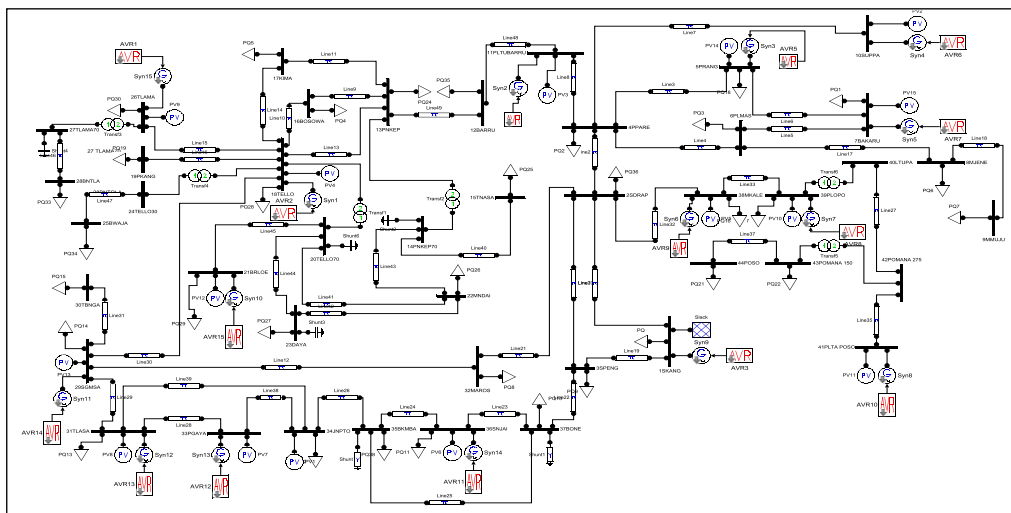

**Figure 1.** The Sulbagsel Interconnection Power Grid Model Use PSAT

2.2. *Double Feed Induction Generator (DFIG)*

Double Feed Induction Generator (DFIG) is one type of wind turbine used in this simulation. The DIFG selection is considered suitable to represent the type of wind turbine that will enter in Sulbagsel interconnection system. DFIG power generated output depends on the reference power used. DFIG uses maximum power point tracking (MPPT). Figure 2 shows the DIFG system.

DFIG is an induction generator with two types of output (fed) used at variable speed PLTB [13]. Unlike the conventional, singly-fed induction generator, DFIG electrical power does not depend on speed. So, it is possible to realize variable speed wind generators by determining the mechanical speed at wind speed and improving turbine operation at an aerodynamic optimal point for a certain wind speed rating.

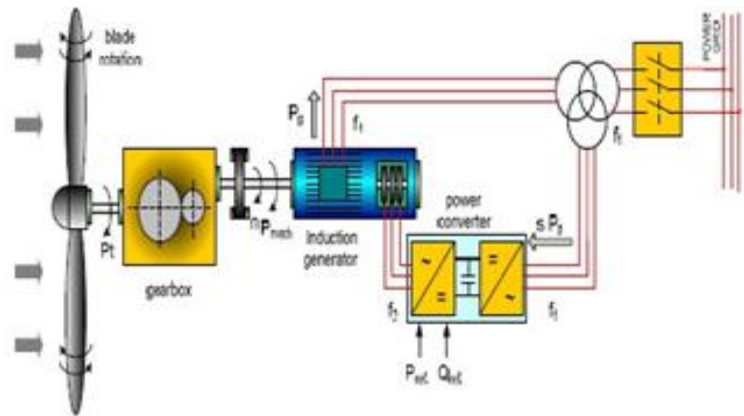

Figure 2. System Double Fed Induction Generator (DFIG)

2.3. *Power System Stabilizer (PSS)*

Inadequate response can cause oscillation of frequency in long period. This will result in reduced power transfer power that can be overcome using PSS. Implementation of a PSS in the power system connected to the stabilizer port that can be seen in Figure 3.

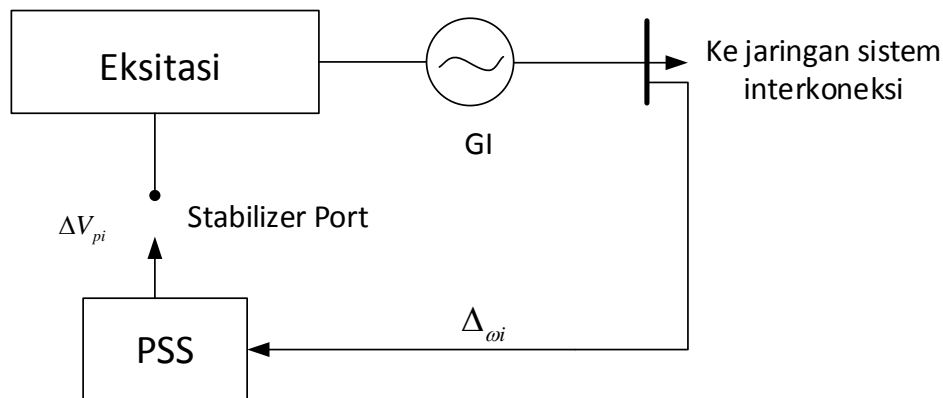
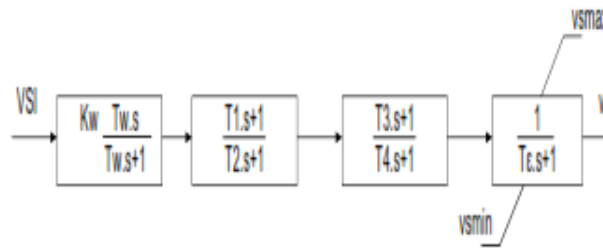

Figure 3. A PSS System in the i-Generator

PSAT provides of five PSS models [4]. The PSS model used in this study is type II model shown in Figure 4.



**Figure 4.** Second type of PSS

where :

$K_w$  = Stabilizer gain

$T_w$  = Wash-out time constant

$T_1$  = First stabilizer time constant

$T_2$  = Second stabilizer time constant

$T_3$  = Third stabilizer time constant

$T_4$  = Fourth stabilizer time constant

$T_\epsilon$  = Small time constant

### 3. Case Study

In this case study, the researcher discuss about the study of transient stability after entry of wind turbine in Sulbagsel interconnection system. Figure 1 shows the modeling of the electrical interconnection system in PSAT Sulbagsel. The dynamic parameters of each plant are shown in Table 1. Power flow is used to see the system responses and time domain simulation for see the response of the generator during the disturbance [13]. The simulation will be done in two stages. The first stage modeled by system with the entry of wind turbine on Sidrap and Jeneponto buses and then given 3 phase disturbances to the ground. The second stage of adding PSS devices in the system to see the damping response of each generator rotor angle velocity ( $\omega$ ) in the event of a transient disturbance.

**Table 1.** Dynamic Parameter Dynamic Parameter Data

No	Pembangkit	$X_d$ (pu)	$X'_d$ (pu)	$X''_d$ (pu)	$X_q$ (pu)	$X'_q$ (pu)	$X''_q$ (pu)	ra (pu)	xl (pu)
1	PLTA Bakar	0,924	0,268	0,27	0,553	0,276	0,27	0	0.12
2	PLTA Teppo (Pinrang)	2,08	0,385	0,261	1,12	0,274	0,261	0	0.186
3	PLTD Suppa	2,08	0,385	0,261	1,12	0,267	0,261	0	0,186
4	PLTU Barru	2,363	0,199	0,204	2,182	0,395	0,204	0	0.107
5	PLTU Tello	1,182	0,0995	0,102	1,091	0,1975	0,102	0	0.107
6	PLTD Agrekko (Tello Lama)	2,363	0,199	0,204	2,182	0,395	0,204	0	0.107
7	PLTD Sgmnsa	2,08	0,385	0,261	1,12	0,337	0,261	0	0.186
8	PLTU Arena (Jeneponto)	2,08	0,385	0,261	1,12	0,485	0,261	0	0.186
9	PLTA Tangka Manipi Sinjai	1,924	0,268	0,27	1,553	0,256	0,27	0	0.12
10	PLTGU Sengkang	2,31	0,2	0,12	0,553	0,6	0,12	0	0.6
11	PLTD Malea (Toraja)	2,08	0,385	0,261	1,12	0,337	0,261	0	0.186
12	PLTD Palopo	2,08	0,385	0,261	1,12	0,337	0,261	0	0.186
13	PLTA Bili-Bili	2,08	0,385	0,261	1,12	0,330	0,261	0	0.186
14	PLTA Poso	0,924	0,268	0,27	0,553	0,368	0,27	0	0.12
15	PLTD Tallasa	2,08	0,385	0,261	1,12	0,485	0,261	0	0.186

3 phase interruption is placed in the middle of lane Sengkang bus with fault time 0.05 second and fault clearing time 0.10 second. For the first interval breaker is 0.5 second and 1.0 for the second

intervention. There are 44 buses, 47 lines, 6 transformers, 15 generators and 34 loads that will be used in this research. The study will use a conventional thermal generating unit, which the Governor Turbine (TG) is used for Model 1, while the Hydroelectric unit uses the Model 3 TG applied to the entire system. As for wind turbines in the wind speed setting with nominal value around 15.00 (m/s).

#### 4. Results and Discussions

The simulated results are rotor angle velocity ( $\omega$ ) and each generating unit power flow studies after the entry of the wind turbine in Sulbagsel interconnection system before and after the addition of the PSS device in the transient state. Time domain simulation is used to obtain angular rotor speed ( $\omega$ ).

Table 2 shows the power flow before and after the application of PSS on the system when a transient disturbance occurs. It can be seen that the stresses on each bus application of PSS decreased significantly below the tolerance limits permitted by the Regulatory Commission of the Energy Regulatory Commission in N-0 conditions (0.95-1.05 p.u.). Conversely, after the voltage of PSS application has improved or increased on almost all of buses when transient disturbance occurs in the system.

**Table 2.** Power Flow Before and after PSS Device Installation

No Bus	Name Bus	Without SPSS		With Spss		Load Flow 2 Conditions			
		V	Phase	V	Phase	Generator		Load	
		[p,u]	[rad]	[p,u]	[rad]	[p,u]	[p,u]	[p,u]	[p,u]
1	Sengkang	0.72	-20.01	0.99	-13.33	1.558	0.266	0.284	0.115
2	Sidrap	0.70	-20.72	0.90	-13.67	0.000	0.000	0.265	0.103
3	Soppeng	0.57	-20.32	0.94	-13.49	0.000	0.000	0.141	0.034
4	Parepare	0.80	-20.79	0.94	-13.73	0.000	0.000	0.187	0.047
5	Pinrang	0.84	-20.80	0.95	-13.73	0.143	-0.425	0.044	0.062
6	Polmas	0.85	-20.84	0.97	-13.73	0.000	0.000	0.171	0.041
7	Bakaru	0.92	-20.84	1.01	-13.77	0.163	0.886	0.150	0.021
8	Majene	0.83	-20.90	0.93	-13.83	0.000	0.000	0.233	0.037
9	Mamuju	0.82	-20.91	0.93	-13.84	0.000	0.000	0.096	0.048
10	Suppa	0.82	-20.78	0.95	-13.72	0.311	-0.097	0.000	0.000
11	PLTU Barru	0.77	-20.79	0.92	-13.75	0.604	-0.186	0.000	0.000
12	Barru	0.73	-20.84	0.93	-13.80	0.000	0.000	0.101	0.024
13	Pangkep	0.64	-20.95	0.95	-13.89	0.000	0.000	0.221	0.080
14	Pangkep70	0.65	-20.92	1.00	-14.05	0.000	0.000	0.000	-0.134
15	Tonasa	0.65	-20.93	0.99	-14.06	0.000	0.000	0.189	0.021
16	Bosowa	0.64	-20.97	0.95	-13.90	0.000	0.000	0.331	0.015
17	Kima	0.63	-20.97	0.96	-13.89	0.000	0.000	0.180	0.058
18	Tello	0.62	-20.99	0.98	-13.89	0.210	3.440	0.633	0.183
19	Panakukang	0.59	-21.04	0.93	-13.94	0.000	0.000	0.683	0.177
20	Tello70	0.70	-20.72	0.97	-14.20	0.000	0.000	0.000	-0.215
21	Borongloe	0.76	-20.59	0.92	-14.24	0.052	-0.280	0.114	0.000
22	Mandai	0.69	-20.75	0.96	-14.21	0.000	0.000	0.243	0.026
23	Daya	0.70	-20.74	0.97	-14.21	0.000	0.000	0.245	-0.186
24	Tello30	0.62	-20.99	0.98	-13.89	0.000	0.000	0.000	0.000
25	Barawaja	0.62	-20.99	0.98	-13.89	0.000	0.000	0.000	0.000

26	T.Lama	0.62	-20.98	0.96	-13.90	0.226	-0.668	0.197	0.047
27	T.Lama70	0.63	-21.09	0.97	-14.01	0.000	0.000	0.000	-0,124
28	Bontoala	0.62	-21.11	0.96	-14.03	0.000	0.000	0.265	0.077
29	Sungguminasa	0.48	-21.00	0.94	-13.81	0.200	-1.104	0.157	0.036
30	Tanjung Bunga	0.47	-21.02	0.92	-13.84	0.000	0.000	0.552	0.167
31	Tallasa	0.00	-20.60	0.93	-13.57	0.790	0.501	0.206	0.047
32	Maros	0.65	-20.77	0.91	-13.71	0.000	0.000	0.186	0.005
33	Pagayya	0.00	-26.23	0.94	-13.47	1,961	-0.371	0.000	0.0000
34	Jeneponto	0.04	-81049	0.94	-13.48	0.625	0.001	0.174	0.034
35	Bulukumba	0.00	-18.06	0.95	-13.54	0.000	0.000	0.271	-0.001
36	Sinjai	0.30	-20.45	0.97	-13.54	0.040	0.070	0.009	0.006
37	Bone	0.37	-20.39	0.95	-13.54	0.000	0.000	0.321	0.016
38	Makale	0.69	-20.77	0.69	-13.44	0.008	0.274	0.119	0.015
39	Palopo	0.50	-20.65	0.48	-13.26	0.004	0.049	0.492	0.073
40	Latuppa	0.00	0.49	0.00	-12.31	0.000	0.000	0.000	0.000
41	PLTA Poso	0.39	32.17	0.34	-10.36	1.950	0.258	0.000	0.000
42	Pomana 275	0.33	32.18	0.29	-10.35	0.000	0.000	0.000	0.000
43	Pomana 150	0.33	32.17	0.29	-10;37	0.000	0.000	0.049	0.005
44	Poso	0.32	32.02	0.95	0.18	0.000	0.000	0.995	0.018

Figure 5 shows a graph of rotor angle velocity ( $\omega$ ) when a transient disturbance occurs prior to the application of PSS. It also shows the angle of the rotor coming out of its inertia moment due to a system interruption. Most of the generators have been off sync which resulted in a blackout on the system interconnection in Sulbagsel.

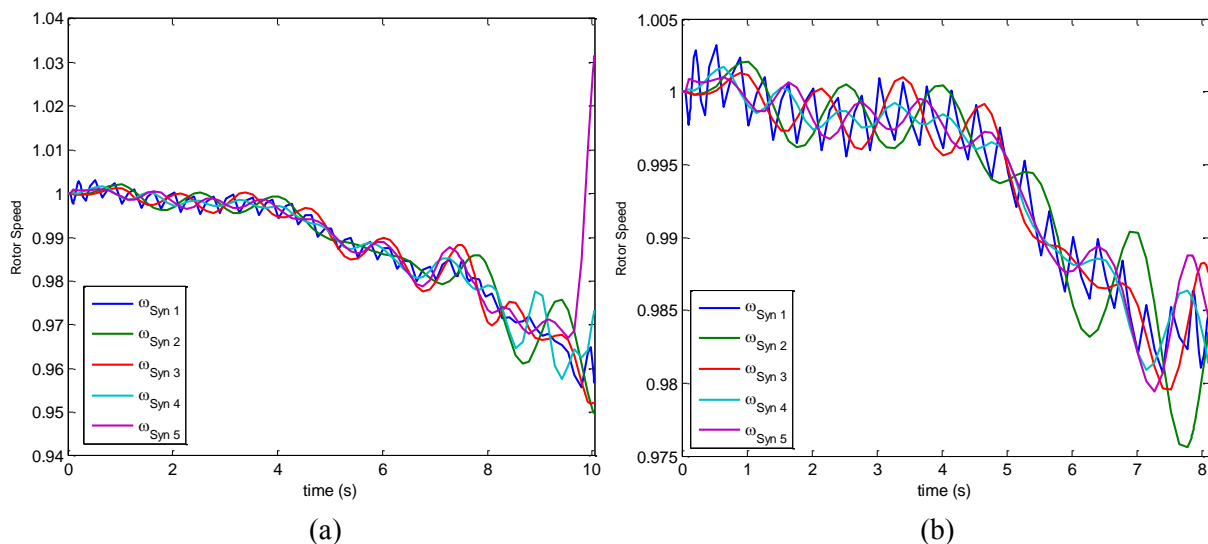

**Figure 5.** Graph of Rotor angle velocity for generator 1-5. (a) Without PSS, (b) With PSS

Figures 5a and 5b show the rotor angle velocity of generator 1-5. From the graph, it is seen that the rotor angle velocity ( $\omega$ ) is able to dampen and maintain the velocity condition at the limit of 0.98 (rad / s) in the appeal without using PSS during the application of transient disturbance PSS.

Figures 6a and 6b show the same thing in generator 6-10. Where the application of PSS is able to reduce transient noise and maintain the density at the limit of 0.98 (rad / s). Compared without using PSS, the rotor angle density continued to decline to below 0.96 (rad / s). This condition indicates that the influence of the entry of the PLTB which impact on the change of tupologi Sulbagsel network also influence system stability when transient disturbance occurs.

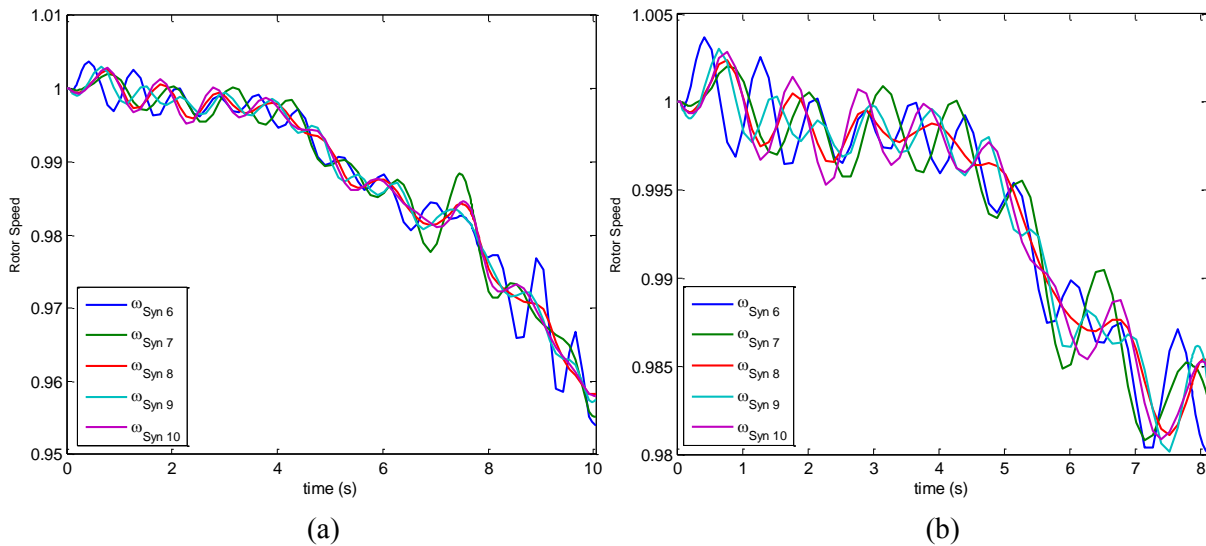

**Figure 6.** Graph of Rotor angle velocity for generator 6-10. (a) Without PSS, (b) With PSS

Figures 7a and 7b show slightly different things. The speed of the generator fluctuates with the density. Specifically for generator 14, the density increases 1.7 (rad/s) before PSS is installed in the system. After PSS is installed in the system, the rotor angle velocity of the generator 14 decreases below 1.1 (rad / s). Graph below is the presented of Figure 7a and Figure 7b.

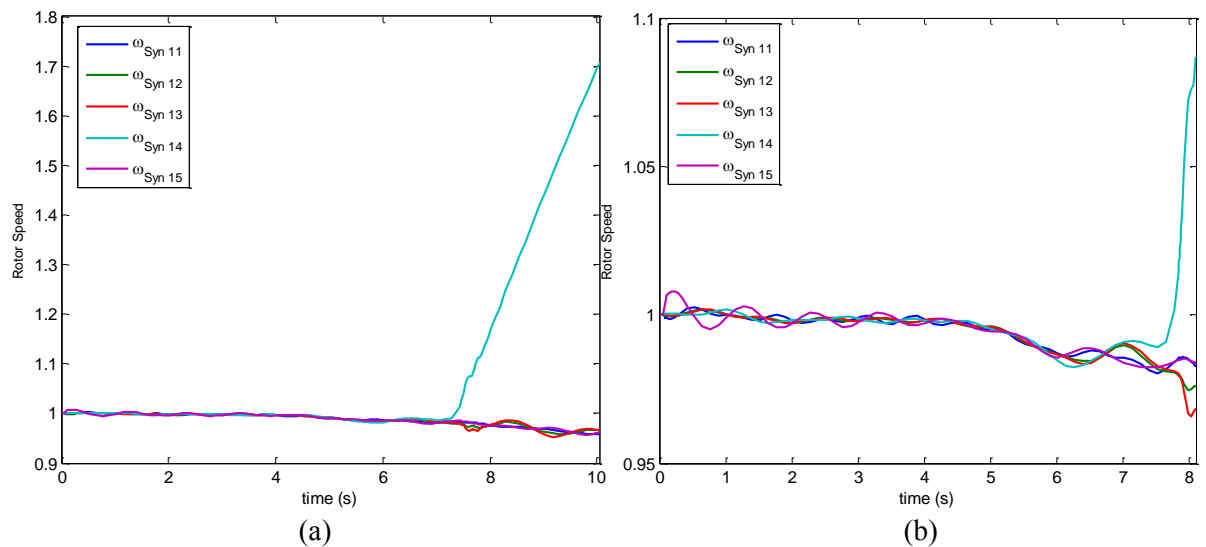

**Figure 7.** Graph of Rotor angle velocity for generator 11-15. (a) Without PSS, (b) With PSS

## 5. Conclusions

The TDS approach, which is an indirect method of solving three phase problems and analyzing the transient stability when the entry of wind turbine in the Sulbagsel interconnection system provides satisfactory results in the stability study of the system. From the results of research using TDS method it is found that the system voltage decreased quite extreme when the disturbance occurred. After the addition of PSS control devices mounted on the generator is able to reduce the deviation of the rotor angle and maintain the speed of the rotor angle to find a new equilibrium point. For further research can use a larger case study and control equipment such as STATCOM, UPFC or TCSC in analyzing the transient stability.

## References

- [1] Anju G P, Thomas P C, Sreeranjini K., Sarin B and Sasidhran S 2013 *J. Sci. Eng. Res* **4**
- [2] Indar C G, Soeprijanto A and Penangsang O 2012 *International Review of Electrical Engineering* vol xx
- [3] Indar C G, Soeprijanto A and Penangsang O 2012 *International Review of Electrical Engineering* vol xx
- [4] Gamit M G., Jigar S S 2015 *Int. J. Res. Eng. Technol* **4(3)** 604–613
- [5] Indar C G, Sri M S and Muhammad I 2016 *J. Theor. Appl. Inf. Technol* **90(1)** 161–167
- [6] Anil K N, Ramesh K 2007 *I* **2(3)** 38–45
- [7] Federico M 2005 *IEEE Transaction On Power Systems* **20(3)** 1199–1206
- [8] Rahul R R, Visakhan R, Sebin J, Aney S V 2015 *Int. J. Innov. Res. Sci. Eng. Technol* **4(11)** 11437–11446.
- [9] Federico M, Luigi V and Juan C 2008 *IEEE Transactions on Education* **51(1)** 17–23
- [10] Jeevajothi R and Devaraj D 2012 *Int. J. Comput. Electr. Eng.* **2(5)** 259–265.
- [11] Ardiaty A and Muhammad B N 2016 *ICITACEE* p 169–172.
- [12] Yuwa C, et al 2012 *IEEE* p 1–8
- [13] Mustadir D, Ansar S, Indar C G 2017 *Analisis Stabilitas Small Signal Saat Masuknya PLTB Pada Sistem Interkoneksi Sulbagsel, Tesis* (Makassar: Hasanuddin University)